Fittings made from unplasticized poly(vinyl chloride) (PVC-U), chlorinated poly(vinyl chloride) (PVC-C) or acrylonitrile/butadiene/styrene (ABS) with plain sockets for pipes under pressure —

**Part 1:
Metric series**

Raccords en poly(chlorure de vinyle) non plastifié (PVC-U), en poly(chlorure de vinyle) chloré (PVC-C) ou en acrylonitrile/butadiène/styrène (ABS), à emboîtements lisses pour tubes sous pression —

Partie 1: Série métrique



Reference number
ISO 727-1:2002(E)

© OSI 2002

www.parsethylen-kish.com

Foreword

ISO (the International Organization for Standardization) is a worldwide federation of national standards bodies (ISO member bodies). The work of preparing International Standards is normally carried out through ISO technical committees. Each member body interested in a subject for which a technical committee has been established has the right to be represented on that committee. International organizations, governmental and non-governmental, in liaison with ISO, also take part in the work. ISO collaborates closely with the International Electrotechnical Commission (IEC) on all matters of electrotechnical standardization.

International Standards are drafted in accordance with the rules given in the ISO/IEC Directives, Part 3.

Draft International Standards adopted by the technical committees are circulated to the member bodies for voting. Publication as an International Standard requires approval by at least 75 % of the member bodies casting a vote.

Attention is drawn to the possibility that some of the elements of this part of ISO 727 may be the subject of patent rights. ISO shall not be held responsible for identifying any or all such patent rights.

International Standard ISO 727-1 was prepared by Technical Committee ISO/TC 138, *Plastics pipes, fittings and valves for the transport of fluids*, Subcommittee SC 2, *Plastics pipes and fittings for water supplies*.

Together with ISO 727-2, this first edition of ISO 727-1 cancels and replaces ISO 727:1985, which has been technically revised.

ISO 727 consists of the following parts, under the general title *Fittings made from unplasticized poly(vinyl chloride) (PVC-U), chlorinated poly(vinyl chloride) (PVC-C) or acrylonitrile/butadiene/styrene (ABS) with plain sockets for pipes under pressure*:

- Part 1: Metric series
- Part 2: Inch-based series

www.parsethylen-kish.com

Fittings made from unplasticized poly(vinyl chloride) (PVC-U), chlorinated poly(vinyl chloride) (PVC-C) or acrylonitrile/butadiene/styrene (ABS) with plain sockets for pipes under pressure —

Part 1: Metric series

1 Scope

This part of ISO 727 specifies the dimensions of plain sockets (cylindrical and conical) in fittings made from unplasticized poly(vinyl chloride) (PVC-U), chlorinated poly(vinyl chloride) (PVC-C) or acrylonitrile/butadiene/styrene (ABS), intended for connecting by solvent cementing to pipes of the corresponding material for use under pressure. The resulting joint does not require mechanical anchorage.

NOTE It is strongly recommended that the advice of the fittings manufacturer be sought in the selection of an appropriate type of solvent cement, depending upon whether the cylindrical or conical type of socketed fitting is being used for a particular installation.

2 Normative reference

The following normative document contains provisions which, through reference in this text, constitute provisions of this part of ISO 727. For dated references, subsequent amendments to, or revisions of, this publication do not apply. However, parties to agreements based on this part of ISO 727 are encouraged to investigate the possibility of applying the most recent edition of the normative document indicated below. For undated references, the latest edition of the normative document referred to applies. Members of ISO and IEC maintain registers of currently valid International Standards.

ISO 161-1:1996, *Thermoplastics pipes for the conveyance of fluids — Nominal outside diameters and nominal pressures — Part 1: Metric series*

3 Terms and definitions

For the purposes of this part of ISO 727, the following terms and definitions apply.

3.1

cylindrical socket

plain socket having a generally cylindrical form with similar root and mouth dimensions

NOTE 1 In practice, such sockets are manufactured with a slight taper in order to assist in removing the moulded fitting from the moulding tool (see clause 6).

NOTE 2 The term parallel socket is used in some countries as a term equivalent to cylindrical socket.

3.2

conical socket

plain socket having a designed taper opening up from root to mouth, and having less clearance than a cylindrical socket

NOTE The term tapered socket is used in some countries as a term equivalent to conical socket.

3.3

mean inside diameter at mid-point of socket depth

d_m

arithmetic mean of two diameters measured at right angles to each other at the mid-point of the socket depth

4 Socket length

For cylindrical sockets, the minimum socket length L (see Figure 1) shall conform to Table 1. For conical sockets (see Figure 2), the minimum socket length L shall conform to Table 2.

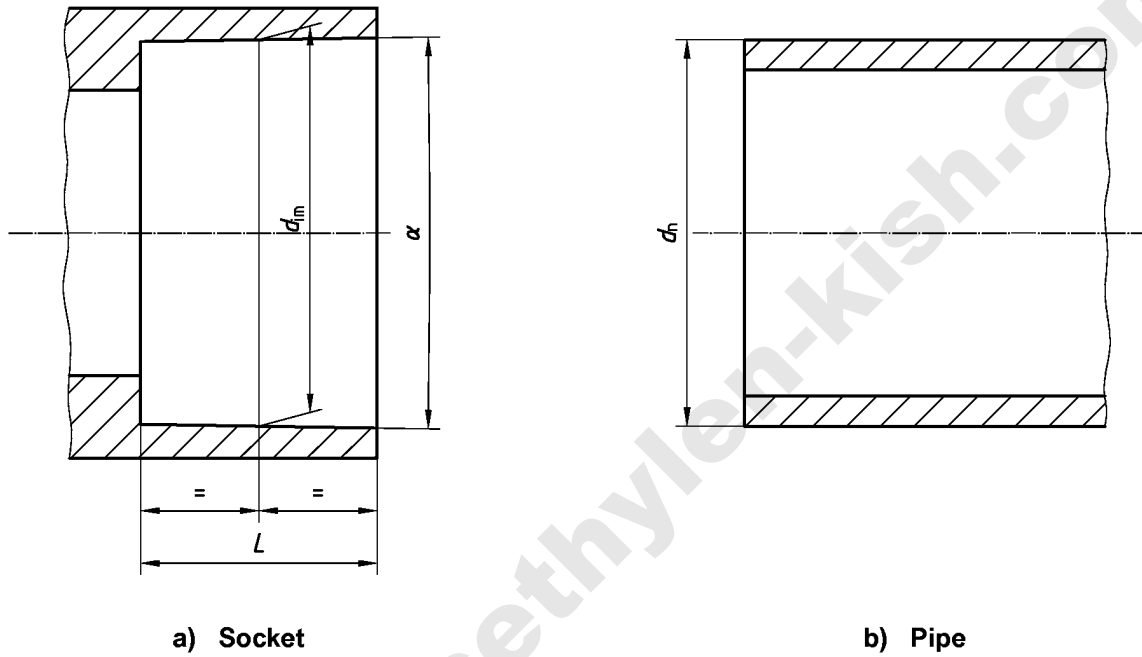

Figure 1 — Dimensions of cylindrical sockets

Table 1 — Dimensions of cylindrical sockets

Dimensions in millimetres

Nominal outside diameter d_n	Minimum socket length ^a L	Mean inside diameter at mid-point of socket depth		Out-of-roundness ^b max.
		min. d_{im}	max.	
10	12	10,1	10,3	0,25
12	12	12,1	12,3	0,25
16	14	16,1	16,3	0,25
20	16	20,1	20,3	0,25
25	18,5	25,1	25,3	0,25
32	22	32,1	32,3	0,25
40	26	40,1	40,3	0,25
50	31	50,1	50,3	0,3
63	37,5	63,1	63,3	0,4
75	43,5	75,1	75,3	0,5
90	51	90,1	90,3	0,6
110	61	110,1	110,4	0,7
125	68,5	125,1	125,4	0,8
140	76	140,2	140,5	0,9
160	86	160,2	160,5	1
180	96	180,2	180,6	1,1
200	106	200,2	200,6	1,2
225	118,5	225,3	225,7	1,4
250	131	250,3	250,8	1,5
280	146	280,3	280,9	1,7
315	163,5	315,4	316	1,9
355	183,5	355,5	356,2	2,2
400	206	400,5	401,5	2,4

^a The above-mentioned values for the minimum socket length related to cylindrical sockets made from PVC-U are calculated by the following equation: $L = 0,5d_n + 6$ mm, with a minimum socket length of 12 mm.

Due to the shrinkage behaviour of cylindrical sockets made from PVC-C and ABS, the socket lengths are calculated by the following equation: $L = 0,5d_n + 5$ mm.

^b The tolerances for the out-of-roundness are rounded values obtained from those in ISO 11922-1:1997, grade M, by multiplying by 0,25.

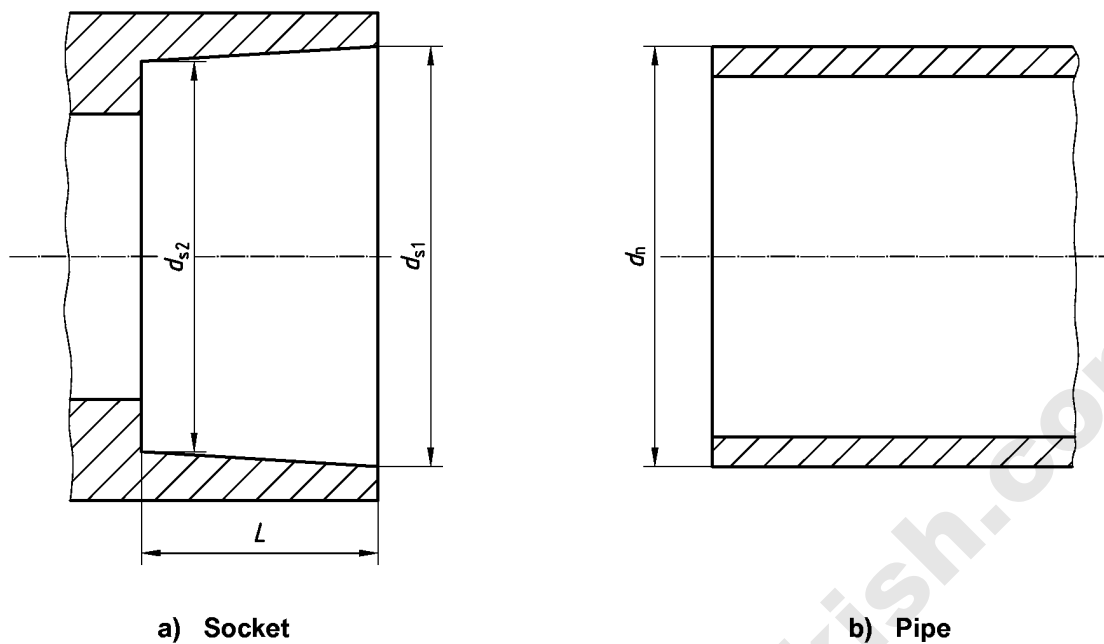

Figure 2 — Dimensions of conical sockets

Table 2 — Dimensions of conical sockets

Dimensions in millimetres

Nominal outside diameter d_n	Minimum socket length L	Mean inside diameter				Out-of-roundness max.
		Socket mouth d_{s1}		Socket root d_{s2}		
		min.	max.	min.	max.	
12	12	12,25	12,45	11,9	12,1	0,25
16	16	16,25	16,45	15,9	16,1	0,25
20	20	20,25	20,45	19,9	20,1	0,25
25	25	25,25	25,45	24,9	25,1	0,25
32	30	32,25	32,45	31,9	32,1	0,25
40	35	40,25	40,45	39,8	40,1	0,25
50	41	50,25	50,45	49,8	50,1	0,3
63	50	63,25	63,45	62,8	63,1	0,4
75	60	75,3	75,6	74,75	75,1	0,5
90	72	90,3	90,6	89,75	90,1	0,6
110	88	110,3	110,6	109,75	110,1	0,7

5 Socket inside diameter

The mean inside diameter of a socket shall be in accordance with the requirements of Table 1 for cylindrical sockets or Table 2 for conical sockets, and is based on the dimensions for thermoplastics pipes included in ISO 161-1.

6 Taper of cylindrical sockets

The maximum included angle α of the socketed portion of a fitting shall not exceed the following values:

$$d_n \leq 63 \text{ mm: } 0^\circ 40'$$

$$75 \text{ mm} \leq d_n \leq 315 \text{ mm: } 0^\circ 30'$$

$$355 \text{ mm} \leq d_n \leq 400 \text{ mm: } 0^\circ 15'$$

7 Marking

The identification of the different types of plain socket (cylindrical and conical) shall be reflected in the minimum required marking for the relevant product and shall be included in the corresponding product standard.

Bibliography

- [1] ISO 11922-1:1997, *Thermoplastics pipes for the conveyance of fluids — Dimensions and tolerances — Part 1: Metric series*

www.parsethylen-kish.com

www.parsethylen-kish.com