



DPC: 08/30191150 DC

Head Office

389 Chiswick High Road
London W4 4AL

Telephone: +44(0)20 8996 9000
Fax: +44(0)20 8996 7001

Date: 18 December 2008

Origin: European

Latest date for receipt of comments: 31 March 2009

Project no.: 2008/03314

Responsible committee: PRI/88/2 Plastics piping for pressure applications

Interested committees:

Title: Draft BS EN 1555-3 Plastics piping systems for the supply of gaseous fuels - Polyethylene (PE)
Part 3: Fittings

Supersession information: If this document is published as a standard, the UK implementation of it will supersede BSEN1555-3 : 2002 and partially supersede. NONE If you are aware of a current national standard which may be affected, please notify the secretary (contact details below).

**WARNING: THIS IS A DRAFT AND MUST NOT BE REGARDED OR USED AS A BRITISH STANDARD.
THIS DRAFT IS NOT CURRENT BEYOND 31 March 2009.**

This draft is issued to allow comments from interested parties; all comments will be given consideration prior to publication. No acknowledgement will normally be sent. **See overleaf for information on commenting.**

No copying is allowed, in any form, without prior written permission from BSI except as permitted under the Copyright, Designs and Patent Act 1988 or for circulation within a nominating organization for briefing purposes. Electronic circulation is limited to dissemination by e-mail within such an organization by committee members.

Further copies of this draft may be purchased from BSI Customer Services, Tel: +44(0) 20 8996 9001 or email cservices@bsigroup.com. British, International and foreign standards are also available from BSI Customer Services.

Information on the co-operating organizations represented on the committees referenced above may be obtained from the responsible committee secretary.

Cross-references

The British Standards which implement International or European publications referred to in this draft may be found via the British Standards Online Service on the BSI web site <http://www.bsigroup.com>.

Responsible Committee Secretary: Committee Service
Centre (BSI)

Direct tel: 020 8996 7009

E-mail: csc@bsigroup.com

Introduction

This draft standard is based on European discussions in which the UK has taken an active part. Your comments on this draft are welcome and will assist in the preparation of the consequent British Standard. Comment is particularly welcome on national, legislative or similar deviations that may be necessary.

Even if this draft standard is not approved by the UK, if it receives the necessary support in Europe, the UK will be obliged to publish the official English Language text unchanged as a British Standard and to withdraw any conflicting standard.

UK Vote

Please indicate whether you consider the UK should submit a negative (with reasons) or positive vote on this draft.

Submission

The guidance given below is intended to ensure that all comments receive efficient and appropriate attention by the responsible BSI committee. **Annotated drafts are not acceptable and will be rejected.**

All comments must be submitted, preferably electronically, to the Responsible Committee Secretary at the address given on the front cover. Comments should be compatible with Version 6.0 or Version 97 of Microsoft® Word for Windows™, if possible; otherwise comments in ASCII text format are acceptable. **Any comments not submitted electronically should still adhere to these format requirements.**

All comments submitted should be presented as given in the example below. Further information on submitting comments and how to obtain a blank electronic version of a comment form are available from the BSI web site at: <http://www.bsigroup.com/en/Standards-and-Publications/Current-work/DPCs/>

Template for comments and secretariat observations

Date: xx/xx/200x

Document: **ISO/DIS xxxxx**

1	2	(3)	4	5	(6)	(7)
MB	Clause No./ Subclause No./ Annex (e.g. 3.1)	Paragraph/ Figure/Table/ Note (e.g. Table 1)	Type of comment	Comment (justification for change) by the MB	Proposed change by the MB	Secretariat observations on each comment submitted
	3.1	Definition 1	ed	Definition is ambiguous and needs clarifying.	Amend to read '... so that the mains connector to which no connection ...'	
	6.4	Paragraph 2	te	The use of the UV photometer as an alternative cannot be supported as serious problems have been encountered in its use in the UK.	Delete reference to UV photometer.	

Microsoft and MS-DOS are registered trademarks, and Windows is a trademark of Microsoft Corporation.

December 2008

ICS 23.040.45; 91.140.40

Will supersede EN 1555-3:2002

English Version

**Plastics piping systems for the supply of gaseous fuels -
Polyethylene (PE) - Part 3: Fittings**

Systèmes de canalisations en plastique pour la distribution
de combustibles gazeux - Polyéthylène (PE) - Partie 3:
Raccords

Kunststoff-Rohrleitungssysteme für die Gasversorgung -
Polyethylen (PE) - Teil 3: Formstücke

This draft European Standard is submitted to CEN members for enquiry. It has been drawn up by the Technical Committee CEN/TC 155.

If this draft becomes a European Standard, CEN members are bound to comply with the CEN/CENELEC Internal Regulations which stipulate the conditions for giving this European Standard the status of a national standard without any alteration.

This draft European Standard was established by CEN in three official versions (English, French, German). A version in any other language made by translation under the responsibility of a CEN member into its own language and notified to the CEN Management Centre has the same status as the official versions.

CEN members are the national standards bodies of Austria, Belgium, Bulgaria, Cyprus, Czech Republic, Denmark, Estonia, Finland, France, Germany, Greece, Hungary, Iceland, Ireland, Italy, Latvia, Lithuania, Luxembourg, Malta, Netherlands, Norway, Poland, Portugal, Romania, Slovakia, Slovenia, Spain, Sweden, Switzerland and United Kingdom.

Recipients of this draft are invited to submit, with their comments, notification of any relevant patent rights of which they are aware and to provide supporting documentation.

Warning : This document is not a European Standard. It is distributed for review and comments. It is subject to change without notice and shall not be referred to as a European Standard.



EUROPEAN COMMITTEE FOR STANDARDIZATION
COMITÉ EUROPÉEN DE NORMALISATION
EUROPÄISCHES KOMITEE FÜR NORMUNG

Management Centre: rue de Stassart, 36 B-1050 Brussels

Contents

Page

Foreword.....	4
Introduction	5
1 Scope.....	6
2 Normative references	6
3 Terms and definitions, symbols and abbreviations	8
4 Material.....	9
4.1 Compound	9
4.2 Material for non-polyethylene parts	9
4.2.1 General.....	9
4.2.2 Metal parts	9
4.2.3 Elastomers.....	9
4.2.4 Other materials.....	9
5 General characteristics	10
5.1 Appearance.....	10
5.2 Colour.....	10
5.3 Design	10
5.4 Appearance of the joint (factory-made).....	10
5.5 Electrical characteristics for electrofusion fittings.....	10
6 Geometrical characteristics	11
6.1 Measurement of dimensions	11
6.2 Dimensions of electrofusion socket fittings	11
6.2.1 Diameters and lengths of sockets.....	11
6.2.2 Wall thicknesses	12
6.2.3 Out-of-roundness of the bore of a fitting (at any point).....	13
6.2.4 Spigots	13
6.2.5 Other dimensions.....	13
6.3 Dimensions of electrofusion saddle fittings	13
6.4 Dimensions of spigot end fittings	14
6.4.1 Diameters and lengths	14
6.4.2 Wall thickness of the fusion end	15
6.4.3 Wall thickness of the fitting body.....	16
6.4.4 Other dimensions.....	16
6.5 Dimensions of mechanical fittings.....	16
6.5.1 General.....	16
6.5.2 Mechanical fittings with polyethylene spigot ends	16
6.5.3 Mechanical fittings with polyethylene electrofusion sockets	16
6.5.4 Threads	16
7 Mechanical characteristics	16
7.1 General.....	16
7.2 Requirements	17
7.3 Performance requirements	19
8 Physical characteristics	19
8.1 Conditioning.....	19
8.2 Requirements	19

9	Performance requirements	20
10	Marking	20
10.1	General	20
10.2	Minimum required marking	20
10.3	Additional marking	21
11	Delivery conditions	21
	Annex A (informative) Examples of typical terminal connection for electrofusion fittings	22
	Annex B (normative) Short-term pressure test method	24
B.1	Principle	24
B.2	Apparatus	24
B.3	Test piece	24
B.4	Procedure	24
B.5	Test report	25
	Annex C (normative) Tensile test for fitting/pipe assemblies	26
C.1	Principle	26
C.2	Apparatus	26
C.3	Test piece	26
C.4	Procedure	26
C.5	Test report	26
	Bibliography	27

www.parsethylenekish.com

Foreword

This document (prEN 1555-3:2008) has been prepared by Technical Committee CEN/TC 155 "Plastics piping systems and ducting systems", the secretariat of which is held by NEN.

This document is currently submitted to the CEN Enquiry.

This document will supersede EN 1555-3:2002.

It has been prepared in liaison with Technical Committee CEN/TC 234 "Gas supply".

This standard is a part of a System Standard for plastics piping systems of a particular material for a specified application. There are a number of such System Standards.

System Standards are based on the results of the work undertaken in ISO/TC 138 "Plastics pipes, fittings and valves for the transport of fluids", which is a Technical Committee of the International Organization for Standardization (ISO).

They are supported by separate standards on test methods to which references are made throughout the System Standard.

The System Standards are consistent with general standards on functional requirements and on recommended practice for installation.

EN 1555 consists of the following parts, under the general title *Plastics piping systems for the supply of gaseous fuels — Polyethylene (PE)*:

- *Part 1: General*
- *Part 2: Pipes*
- *Part 3: Fittings* (this standard)
- *Part 4: Valves*
- *Part 5: Fitness for purpose of the system*
- *Part 7: Guidance for assessment of conformity* (CEN/TS)

NOTE The document dealing with recommended practice for installation which was initially submitted for CEN enquiry as prEN 1555-6 [1] was withdrawn when EN 12007-2 [1], prepared by CEN/TC 234 *Gas supply*, was published with the title "Gas supply systems - Pipelines for maximum operating pressure up to and including 16 bar – Part 2: Specific functional recommendations for polyethylene (MOP up to and including 10 bar)".

Introduction

The System Standard, of which this is Part 3, specifies the requirements for a piping system and its components made from polyethylene (PE) and which is intended to be used for the supply of gaseous fuels.

Requirements and test methods for material and components, other than fittings, are specified in prEN 1555-1:2008, prEN 1555-2:2008 and prEN 1555-4:2008. Characteristics for fitness for purpose are covered in prEN 1555-5:2008. CEN/TS 1555-7 gives guidance for assessment of conformity. Recommended practice for installation is given in EN 12007-2 [2] prepared by CEN/TC 234.

This part of EN 1555 covers the characteristics of fittings.

www.parsethylene-kish.com

1 Scope

This part of EN 1555 specifies the characteristics of fusion fittings made from polyethylene (PE) as well as of mechanical fittings for piping systems in the field of the supply of gaseous fuels.

It also specifies the test parameters for the test methods referred to in this standard.

In conjunction with the other parts of EN 1555 (see Foreword), it is applicable to PE fittings, their joints and to joints with components of PE and other materials intended to be used under the following conditions:

- a) a maximum operating pressure, MOP, up to and including 10 bar ¹);
- b) an operating temperature of 20 °C as reference temperature.

NOTE 1 For other operating temperatures, derating coefficients should be used, see prEN 1555 5:2008.

EN 1555 covers a range of maximum operating pressures and gives requirements concerning colours and additives.

NOTE 2 It is the responsibility of the purchaser or specifier to make the appropriate selections from these aspects, taking into account their particular requirements and any relevant national regulations and installation practices or codes.

This standard is applicable for fittings of the following types:

- a) electrofusion socket fittings;
- b) electrofusion saddle fittings;
- c) spigot end fittings (for butt fusion using heated tools and electrofusion socket fusion);
- d) mechanical fittings.

The fittings can e.g. be in the form of couplers, equal and reduced tees, reducers, bends or caps.

2 Normative references

The following referenced documents are indispensable for the application of this document. For dated references, only the edition cited applies. For undated references, the latest edition of the referenced document (including any amendments) applies.

EN 682, *Elastomeric seals — Materials requirements for seals used in pipes and fittings carrying gas and hydrocarbon fluids*

prEN 1555-1:2008, *Plastics piping systems for the supply of gaseous fuels — Polyethylene (PE) — Part 1: General*

prEN 1555-2:2008, *Plastics piping systems for the supply of gaseous fuels — Polyethylene (PE) — Part 2: Pipes*

prEN 1555-5:2008, *Plastics piping systems for the supply of gaseous fuels — Polyethylene (PE) — Part 5: Fitness for purpose of the system*

EN 1716, *Plastics piping systems — Polyethylene (PE) tapping tees — Test method for impact resistance of an assembled tapping tee*

¹ 1 bar = 0,1 MPa

- EN 12117, *Plastics piping systems — Fittings, valves and ancillaries — Determination of gaseous flow rate/pressure drop relationships*
- EN 10226-1, *Pipe threads where pressure tight joints are made on the threads — Part 1: Taper external threads and parallel internal threads — Dimensions, tolerances and designation*
- EN 10226-2, *Pipe threads where pressure tight joints are made on the threads — Part 2: Taper external threads and taper internal threads — Dimensions, tolerances and designation*
- EN ISO 1133:2005, *Plastics — Determination of the melt mass-flow rate (MFR) and the melt volume-flow rate (MVR) of thermoplastics* (ISO 1133:2005)
- EN ISO 1167-1:2006, *Thermoplastics pipes, fittings and assemblies for the conveyance of fluids — Determination of the resistance to internal pressure — Part 1: General method* (ISO 1167-1:2006)
- EN ISO 1167-2, *Thermoplastics pipes, fittings and assemblies for the conveyance of fluids — Determination of the resistance to internal pressure — Part 2: Preparation of pipe test pieces* (ISO 1167-2:2006)
- EN ISO 1167-3, *Thermoplastics pipes, fittings and assemblies for the conveyance of fluids — Determination of the resistance to internal pressure — Part 3: Preparation of components* (ISO 1167-3:2007)
- EN ISO 1167-4, *Thermoplastics pipes, fittings and assemblies for the conveyance of fluids — Determination of the resistance to internal pressure — Part 4: Preparation of assemblies* (ISO 1167-4:2007)
- EN ISO 3126, *Plastics piping systems — Plastics piping components — Measurement and determination of dimensions* (ISO 3126:2005)
- ISO 228-1, *Pipe threads where pressure-tight joints are not made on the threads — Part 1: Dimensions, tolerances and designation*
- ISO 10838-1²⁾, *Mechanical fittings for polyethylene piping systems for the supply of gaseous fuels — Part 1: Metal fittings for pipes of nominal outside diameter less than or equal to 63 mm*
- ISO 10838-2²⁾, *Mechanical fittings for polyethylene piping systems for the supply of gaseous fuels — Part 2: Metal fittings for pipes of nominal outside diameter greater than 63 mm*
- ISO 10838-3²⁾, *Mechanical fittings for polyethylene piping systems for the supply of gaseous fuels — Part 3: Thermoplastic fittings for pipes of nominal outside diameter less than or equal to 63 mm*
- ISO/FDIS 11357-6:2008, *Plastics — Differential scanning calorimetry (DSC) — Part 6: Determination of oxidation induction time (isothermal OIT) and oxidation induction temperature (dynamic OIT)*
- ISO 13953, *Polyethylene (PE) pipes and fittings — Determination of the tensile strength and failure mode of test pieces from a butt-fused joint*
- ISO 13954, *Plastics pipes and fittings — Peel decohesion test for polyethylene (PE) electrofusion assemblies of nominal outside diameter greater than or equal to 90 mm*
- ISO 13955, *Plastics pipes and fittings — Crushing decohesion test for polyethylene (PE) electrofusion assemblies*
- ISO/CD 13956:2008, *Plastics pipes and fittings — Determination of cohesive strength — Tear test for polyethylene (PE) assemblies*

² Under revision.

3 Terms and definitions, symbols and abbreviations

For the purposes of this European Standard, the terms and definitions, symbols and abbreviations given in prEN 1555 1:2008 apply, together with the following.

3.1

electrofusion socket fitting

polyethylene (PE) fitting which contains one or more integral heating elements, that are capable of transforming electrical energy into heat to realise a fusion joint with a spigot end or a pipe

3.2

electrofusion saddle fitting

polyethylene (PE) fitting which contains one or more integral heating elements, that are capable of transforming electrical energy into heat to realise a fusion joint onto a pipe

3.2.1

tapping tee

electrofusion saddle fitting (top loading or wrap round) which contains an integral cutter, to cut through the wall of the main pipe

NOTE The cutter remains in the body of the saddle after installation.

3.2.2

branch saddle

electrofusion saddle fitting (top loading or wrap round) which requires an ancillary cutting tool for drilling a hole in the adjoining main pipe

3.3

mechanical fitting

fitting, that generally includes a compression part to provide pressure integrity, leaktightness and resistance to end loads, for assembling polyethylene (PE) pipe to another PE pipe or any other element of the piping system

NOTE 1 A pipe supporting sleeve providing a permanent support for a polyethylene (PE) pipe to prevent creep in the pipe wall under radial compressive forces, is applicable. The metallic parts of the fitting can be assembled to metallic pipes by screw-threads, compression joints, welded or flanged connections, including PE flanges. In some cases the supporting sleeve at the same time constitutes a grip ring.

NOTE 2 The fitting can allow either a dismountable or permanently assembled joint.

NOTE 3 The mechanical fitting can be supplied for field assembly or pre-assembled by the manufacturer.

3.4

spigot end fitting

polyethylene (PE) fitting where the outside diameter of the spigot end is equal to the nominal outside diameter, d_n , of the corresponding pipe

3.5

voltage regulation

control of energy supplied, during the fusion process of an electrofusion fitting, by means of the voltage parameter

3.6

intensity regulation

control of energy supplied, during the fusion process of an electrofusion fitting, by means of the current parameter

4 Material

4.1 Compound

The compound from which the fittings are made shall conform to prEN 1555-1:2008.

4.2 Material for non-polyethylene parts

4.2.1 General

All components shall conform to the relevant EN standard(s). Alternative standards may be applied in cases where the suitable EN standard(s) do not exist. In all cases fitness for purpose of the components shall be demonstrated.

The materials and the constituent elements used in making the fitting (including rubber, greases and any metal parts as may be used) shall be as resistant to the external and internal environments as the other elements of the piping system and shall have a life expectancy under the following conditions at least equal to that of the PE pipes conforming to prEN 1555 2:2008 with which they are intended to be used:

- a) during storage;
- b) under the effect of the gas conveyed therein;
- c) with respect to the service environment and operating conditions.

The requirements for the level of material performance of non-polyethylene parts shall be at least as stringent as that of the compound for the piping system.

Fittings material in contact with the PE pipe shall not adversely affect pipe performance or initiate stress cracking.

4.2.2 Metal parts

All metal parts susceptible to corrosion shall be adequately protected.

When dissimilar metallic materials are used which can be in contact with moisture, steps shall be taken to avoid the possibility of galvanic corrosion.

4.2.3 Elastomers

Elastomeric seals shall conform to EN 682.

Other sealing materials are permitted if suitable for gas service.

4.2.4 Other materials

Greases or lubricants shall not exude onto fusion areas, and shall not affect the long-term performance of fitting materials.

Other materials conforming to 4.2.1 may be used provided that it is proven that the fittings conform to this standard.

5 General characteristics

5.1 Appearance

When viewed without magnification, the internal and external surfaces of fittings shall be smooth, clean and shall have no scoring, cavities and other surface defects to an extent that would prevent conformity to this standard.

No component of the fitting shall show any signs of damage, scratches, pitting, bubbles, blisters, inclusions or cracks to an extent that would prevent conformity of the fittings to the requirements of this standard.

5.2 Colour

The colour of the PE parts of fittings shall be either yellow, orange or black.

5.3 Design

The design of the fitting shall be such that, when assembling the fitting onto the corresponding component, electrical coils and/or seals are not displaced.

5.4 Appearance of the joint (factory-made)

The internal and external surfaces of the pipe and fitting after fusion jointing, examined visually without magnification, shall be free from melt exudation outside the confines of the fitting, apart from that which may be declared acceptable by the fitting manufacturer or used deliberately as a fusion marker.

Any melt exudation shall not cause wire movement in electrofusion fittings such that it leads to short-circuiting, when jointed in accordance with the manufacturer's instructions. There shall be no excessive creasing of the internal surfaces of the adjoining pipes.

5.5 Electrical characteristics for electrofusion fittings

The electrical protection that shall be provided by the fusion process depends on the voltage and the current used and on the characteristics of the electricity power source.

For voltages greater than 25 V, direct human contact with energized parts shall not be possible when the fitting is in the fusion cycle during assembly in accordance with the instructions of the manufacturers of the fittings and of the assembly equipment, as applicable.

NOTE 1 The fitting is during the fusion process part of an electrical system as defined in IEC 60335-1:2006 [3], IEC 60364-1:2005 [4] and IEC 60449:1973 [5].

The tolerance on the electrical resistance of the fitting at 23 °C shall be stated by the manufacturer. The resistance shall not exceed the following value: [nominal value \pm 10 %] + 0,1 Ω .

NOTE 2 0,1 Ω is the assumed value of the contact resistance.

The surface finish of the terminal pins shall allow a minimum contact resistance in order to satisfy the resistance tolerance requirements.

NOTE 3 See Annex A, for examples of typical electrofusion terminal connections.

6 Geometrical characteristics

6.1 Measurement of dimensions

Dimensions shall be measured in accordance with EN ISO 3126 at $(23 \pm 2) ^\circ\text{C}$, after being conditioned for at least 4 h. The measurement shall not be made less than 24 h after manufacture.

NOTE Indirect measurement is allowed at shorter time periods providing evidence is shown of correlation.

6.2 Dimensions of electrofusion socket fittings

6.2.1 Diameters and lengths of sockets

For electrofusion sockets (see Figure 1) having a nominal diameter given in Table 1, the socket diameter and lengths shall be given by the manufacturer and shall conform to Table 1 with the following conditions:

- $L_3 \geq 5 \text{ mm}$;
- $D_2 \geq d_n - 2e_{\min}$

where

- e_{\min} is the minimum wall thickness specified for the corresponding pipe conforming to prEN 1555-2:2008;
- D_1 is the mean inside diameter in the fusion zone measured in a plane parallel to the plane of the mouth at a distance of $L_3 + 0,5L_2$ from that face;
- D_2 is the bore, which is the minimum diameter of the flow channel through the body of the fitting;
- L_1 is the depth of penetration of the pipe or male end of a spigot fitting. In case of a coupling without stop, it is not greater than half the total length of the fitting;
- L_2 is the heated length within a socket as declared by the manufacturer to be the nominal length of the fusion zone;
- L_3 is the distance between the mouth of the fitting and the start of the fusion zone as declared by the manufacturer to be the nominal unheated entrance length of the fitting.

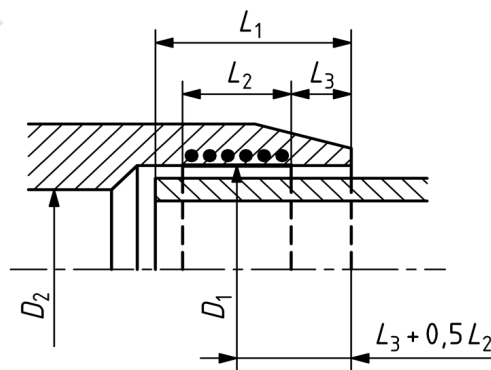

Figure 1 — Dimensions of electrofusion socket fittings

Table 1 — Dimensions of electrofusion socket fittings

Dimensions in millimetres

Nominal diameter d_n	Depth of penetration		$L_{1,max}$	Fusion zone
	$L_{1,min}$			$L_{2,min}$
	Intensity regulation	Voltage regulation		
16	20	25	41	10
20	20	25	41	10
25	20	25	41	10
32	20	25	44	10
40	20	25	49	10
50	20	28	55	10
63	23	31	63	11
75	25	35	70	12
90	28	40	79	13
110	32	53	82	15
125	35	58	87	16
140	38	62	92	18
160	42	68	98	20
180	46	74	105	21
200	50	80	112	23
225	55	88	120	26
250	73	95	129	33
280	81	104	139	35
315	89	115	150	39
355	99	127	164	42
400	110	140	179	47
450	122	155	195	51
500	135	170	212	56
560	147	188	235	61
630	161	209	255	67

The mean inside diameter of the fitting in the middle of the fusion zone (see L_1 in Figure 1) shall be not less than d_n .

The manufacturer shall declare the actual minimum and maximum values of D_1 to allow the end-user to determine their suitability for clamping and joint assembly and fitness for purpose testing in accordance with prEN 1555-5:2008.

In the case of a fitting having sockets of differing nominal diameters, each one shall conform to the requirements for the nominal diameter of the corresponding component.

6.2.2 Wall thicknesses

In order to prevent stress concentrations, any changes in wall thickness of the fitting body shall be gradual.

- a) The wall thickness of the body of the fitting at any point, E , shall be greater than or equal to e_{min} for the corresponding pipe at any part of the fitting located at a distance beyond a maximum of $2L_1/3$ from all entrance faces if the fitting and the corresponding pipe are made from a polyethylene having the same MRS.

If the fitting is produced from a polyethylene having an MRS that is different from that of the corresponding pipe, the relationship between the wall thickness of the fitting, E , and the pipe, e_{\min} , shall be in accordance with Table 2.

Table 2 — Relation between fitting and pipe wall thicknesses

Pipe and fitting material		Relation between fitting wall thickness, E , and pipe wall thickness, e_n
Pipe	Fitting	
PE 80	PE 100	$E \geq 0,8e_n$
PE 100	PE 80	$E \geq e_n/0,8$

- b) In the case of a wall thickness design different from that according to a), fittings and associated fusion joints shall additionally meet the performance requirements given in 7.3.

6.2.3 Out-of-roundness of the bore of a fitting (at any point)

When a fitting leaves the site of the manufacturer, the out-of-roundness of the bore of a fitting at any point shall not exceed $0,015d_n$.

6.2.4 Spigots

For fittings, which contain spigot outlets (e.g. electrofusion equal tee with a spigotted branch), the dimensions of the spigot shall conform to 6.4.

6.2.5 Other dimensions

The dimensional characteristics appropriate to each manufacturer such as the overall dimensions or mounting dimensions shall be specified in a technical file.

In the case of a coupling without an internal stop or with a removable centre register, the geometry of the fitting shall allow the penetration of the pipe through the fitting.

6.3 Dimensions of electrofusion saddle fittings

Outlets from tapping tees and branch saddles shall have spigots conforming to 6.4 or an electrofusion socket conforming to 6.2.

The manufacturer shall specify the overall dimensions of the fitting in a technical file. These dimensions shall include the maximum height of the saddle, H , and for tapping tees the height of the service pipe, H_1 or H_2 (see Figure 2).

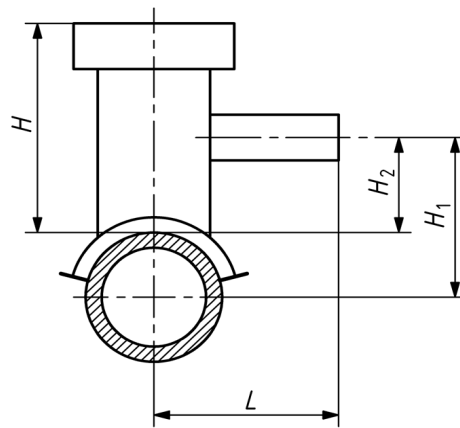

Key

- H height of the saddle, which comprises the distance from the top of the main pipe to the top of the tapping tee or saddle
- H_1 height of service pipe, which comprises the distance from the axis of the main pipe to the axis of the service pipe
- H_2 height of service pipe, which comprises the distance from the top of the main pipe to the axis of the service pipe
- L width of the tapping tee, which comprises the distance between the axis of the pipe and the plane of the mouth of the service tee

Figure 2 — Dimensions of electrofusion saddle fittings

6.4 Dimensions of spigot end fittings

6.4.1 Diameters and lengths

The dimensions of spigot end fittings (see Figure 3) shall conform to the values given in Table 3.

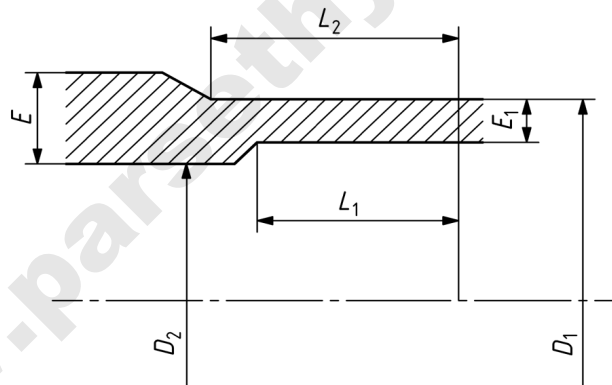

Key

- D_1 "mean outside diameter" of the fusion end, measured in any plane parallel to the plane of the entrance face at a distance not greater than L_2 from that plane;
- D_2 "bore", which is the minimum diameter of the flow channel through the body of the fitting. The measurement of the diameter does not include the fusion bead, if any;
- E "wall thickness of the body of the fitting" measured at any point;
- E_1 "fusion face wall thickness" measured at any point over a distance up to a maximum of L_1 from the entrance face of the spigot;
- L_1 "cut back length" of the inside of the fusion end piece, which is the initial depth of the spigot end necessary for butt fusion;
- L_2 "tubular length" of the outside of the fusion end piece, which is the initial length of the fusion end piece.

Figure 3 — Dimensions of spigot end fittings

The cut back length, L_1 , may also be obtained by jointing a length of pipe to the spigot end fitting provided that the wall thickness of the latter is equal to E_1 for its whole length.

The tubular length shall allow the following operations, in any combination:

- use of clamps required in the case of butt fusion or electrofusion;
- assembly with an electrofusion socket.

Table 3 — Diameters and lengths of spigot end fittings

Dimensions in millimetres

Nominal diameter D_n	Mean outside diameter of the fusion end		Out-of-roundness max.	Minimum bore $D_{2,min}$	Cut back length $L_{1,min}$	Tubular length ^b $L_{2,min}$
	$D_{1,min}$	$D_{1,max}$ ^a				
16	16	16,3	0,3	9	25	41
20	20	20,3	0,3	13	25	41
25	25	25,3	0,4	18	25	41
32	32	32,3	0,5	25	25	44
40	40	40,4	0,6	31	25	49
50	50	50,4	0,8	39	25	55
63	63	63,4	0,9	49	25	63
75	75	75,5	1,2	59	25	70
90	90	90,6	1,4	71	28	79
110	110	110,7	1,7	87	32	82
125	125	125,8	1,9	99	35	87
140	140	140,9	2,1	111	38	92
160	160	161,0	2,4	127	42	98
180	180	181,1	2,7	143	46	105
200	200	201,2	3,0	159	50	112
225	225	226,4	3,4	179	55	120
250	250	251,5	3,8	199	60	129
280	280	281,7	4,2	223	75	139
315	315	316,9	4,8	251	75	150
355	355	357,2	5,4	283	75	164
400	400	402,4	6,0	319	75	179
450	450	452,7	6,8	359	100	195
500	500	503,0	7,5	399	100	212
560	560	563,4	8,4	447	100	235
630	630	633,8	9,5	503	100	255

^a The tolerance grades conform to ISO 11922-1: 1997 [6], Grade B

^b Spigot end fittings may be delivered with shorter tubular length L_2 for factory assemblies or in association with appropriate electrofusion fittings.

6.4.2 Wall thickness of the fusion end

The wall thickness of the fusion end, E_1 , shall be at least equal to the minimum wall thickness of the pipe, except between the plane of the entrance face and a plane parallel to it, located at a distance not greater than $(0,01d_e + 1 \text{ mm})$, where a thickness reduction for e.g. a chamfered edge is permitted.

6.4.3 Wall thickness of the fitting body

The wall thickness, E , of the fitting body measured at any point, shall be at least equal to the nominal wall thickness, e_n , of the pipe.

The permissible tolerance of the wall thickness, E , at any point shall conform to those of the nominal wall thicknesses given in prEN 1555-2:2008.

Any changes in wall thickness inside the body of the fitting shall be gradual in order to prevent stress concentrations.

6.4.4 Other dimensions

The dimensional characteristics appropriate to each manufacturer, such as overall dimensions or clamping requirements shall be stated in a technical file.

6.5 Dimensions of mechanical fittings

6.5.1 General

The dimensions of mechanical fittings shall conform to ISO 10838-1, ISO 10838-2 or ISO 10838-3, as applicable and shall be capable of assembly on to PE pipe conforming to prEN 1555-2:2008.

NOTE The ISO 10838 series of standards will be replaced by a new standard in the future.

The fittings shall be designed and manufactured in such a way that they may be used buried or above ground (see EN 12007:2000 [2]). Pre-assembled mechanical fittings shall not be capable of being dismantled.

The fittings shall be designed to avoid twisting of the PE pipe during assembly.

The fittings shall include, if required, a means for anchoring an anti-shear sleeve.

The fittings shall not be assembled to the PE pipe by screw threads.

6.5.2 Mechanical fittings with polyethylene spigot ends

Polyethylene spigot ends shall conform to 6.4.

6.5.3 Mechanical fittings with polyethylene electrofusion sockets

Electrofusion sockets shall conform to 6.2.

6.5.4 Threads

Threads on metal ends shall conform to EN 10226-1, EN 10226-2 or ISO 228-1, as applicable.

7 Mechanical characteristics

7.1 General

NOTE 1 The properties of a joint depend upon the properties of the pipes and fittings and on the conditions of their installation (i.e. geometry, temperature, type, method of conditioning, mounting or clamping and fusion procedures).

The technical descriptions of the manufacturer shall include the following information:

- a) field of application:
 - pipe and fitting temperature limits;
 - pipe series or SDRs;
 - ovality;
- b) assembly instructions;
- c) fusion instructions:
 - fusion parameters with limits;
- d) data for saddles and tapping tees:
 - the means of attachment (tools and/or underclamp);
 - the need to maintain the underclamp in position in order to ensure the performances of the assembly.

In the event of modification of the fusion parameters, the manufacturer shall ensure that the joint conforms to prEN 1555 5:2008.

NOTE 2 Sample test assemblies should take account of manufacturing tolerances, assembly tolerances and ambient temperature variations at which the fittings can be used. The manufacturer should take due consideration of the recommended practices for installation of PE fittings, given in EN 12007-2:2000 [2].

Fittings shall be tested using pipes, which conform to prEN 1555-2:2008.

Jointed pipe and fitting test pieces shall be assembled in accordance with the technical instructions of the manufacturer and take into account the limit conditions of utilisation described in prEN 1555-5:2008. The sample test assemblies shall take account of manufacturing and assembly tolerances.

In the event of modification of the jointing parameters, the manufacturer shall ensure that the joint conforms to the requirements given in 7.2.

7.2 Requirements

Unless otherwise specified by the applicable test method, the test pieces shall be conditioned at $(23 \pm 2) ^\circ\text{C}$ before testing in accordance with Table 4.

When tested in accordance with the test methods as specified in Table 4 using the indicated parameters, the fittings shall have mechanical characteristics conforming to the requirements given in Table 4, as applicable to the following types of fitting:

- (A) electrofusion socket fitting;
- (B) electrofusion saddle fitting;
- (C) spigot end fitting.

For mechanical fittings, the requirements of ISO 10838-1, ISO 10838-2 or ISO 10838-3, shall apply.

NOTE The ISO 10838 series of standards will be replaced by a new standard in the future.

Table 4 — Mechanical characteristics

Characteristic	Requirements	Test parameters		Test method
		Parameter	Value	
Hydrostatic strength (20 °C, 100 h)	No failure during test period of any test piece	End caps Orientation Conditioning time Number of test pieces ^a Type of test Circumferential (hoop) stress in pipe for: PE 80 PE 100 Test period Test temperature	Type a) of EN ISO 1167-1:2006 Free Shall conform to EN ISO 1167-1:2006 3 Water-in-water 10,0 MPa 12,4 MPa ^b 100 h 20 °C	EN ISO 1167-1 and EN ISO 1167-2, EN ISO 1167-3, or EN ISO 1167-4, as applicable
Hydrostatic strength (80 °C, 165 h)	No failure during test period of any test piece ^c	End caps Orientation Conditioning time Number of test pieces ^a Type of test Circumferential (hoop) stress in pipe for: PE 80 PE 100 Test period Test temperature	Type a) of EN ISO 1167-1:2006 Free Shall conform to EN ISO 1167-1:2006 3 Water-in-water 4,5 MPa 5,4 MPa 165 h 80 °C	EN ISO 1167-1 and EN ISO 1167-2, EN ISO 1167-3, or EN ISO 1167-4, as applicable
Hydrostatic strength (80 °C, 1000 h)	No failure during test period of any test piece	End caps Orientation Conditioning time Number of test pieces ^a Type of test Circumferential (hoop) stress in pipe for: PE 80 PE 100 Test period Test temperature	Type a) of EN ISO 1167-1:2006 Free Shall conform to EN ISO 1167-1:2006 3 Water-in-water 4,0 MPa 5,0 MPa 1000 h 80 °C	EN ISO 1167-1 and EN ISO 1167-2, EN ISO 1167-3, or EN ISO 1167-4, as applicable
Decohesive resistance (A)	Length of initiation rupture $\leq L_2/3$ in brittle failure	Test temperature Number of test pieces ^a	23 °C Shall conform to ISO 13954 and ISO 13955	ISO 13954 ISO 13955
Cohesive strength (B)	Surface of rupture ≤ 25 % brittle failure	Test temperature Number of test pieces ^a	23 °C Shall conform to ISO 13956	ISO 13956
Tensile strength for butt fusion (C)	Test to failure: ductile - pass brittle - fail	Test temperature Number of test pieces ^a	23 °C Shall conform to ISO 13953	ISO 13953
Impact resistance (B)	No failure, no leakage	Test temperature Falling height Mass of the striker Number of test pieces ^a	0 °C 2 m 2,5 kg 1	EN 1716
Pressure drop (B)	Air flow rate (value indicated by the manufacturer)	Test medium Test pressure Pressure drop: for $d_n \leq 63$ mm for $d_n > 63$ mm Number of test pieces ^a	Air source 25 mbar 0,5 mbar 0,1 mbar 1	EN 12117

a The numbers of test pieces given indicate the numbers required to establish a value for the characteristic described in the table. The numbers of test pieces required for factory production control and process control should be listed in the manufacturer's quality plan. For guidance see CEN/TS 1555-7 [2].

b This value is subject to further study by ISO/TC 138/SC5.

c Only brittle failures shall be taken into account. If a ductile failure occurs before 165 h, the test may be repeated at a lower stress. The stress and the associated minimum test period shall be selected from Table 5 or from a line based on the stress/time points given in Table 5.

Table 5 — Circumferential (hoop) stress at 80 °C and associated minimum test period

PE 80		PE 100	
Stress MPa	Minimum test period h	Stress MPa	Minimum test period h
4,5	165	5,4	165
4,4	233	5,3	256
4,3	331	5,2	399
4,2	474	5,1	629
4,1	685	5,0	1000
4,0	1000	—	—

7.3 Performance requirements

Where 6.2.2 b) applies, electrofusion socket fittings shall, additionally, be in accordance with Table 6.

Table 6 — Performance requirements

Characteristics	Requirement	Test parameters		Test method
		Parameter	Value	
Short-term internal pressure resistance	Failure pressure shall be greater than pressure equivalent of $2 \times$ MRS calculated for thickest-walled pipe for which fitting has been designed	End caps Orientation Conditioning time Type of test Minimum pressure: PE 80 pipe, SDR 11 PE 100 pipe, SDR 11 Pressure increase rate Test temperature	Type a) of EN ISO 1167-1:2006 Free 12 h Water-in-water 32 bar 40 bar 5 bar/min 20 °C	Annex B
Resistance to tensile load	Minimum elongation shall be 25 % before pipe yields	Test temperature	23 °C	Annex C
1 bar = 0,1 MPa = 10^5 Pa; 1 MPa = 1 N/mm ²				

8 Physical characteristics

8.1 Conditioning

Unless otherwise specified by the applicable test method, the test pieces shall be conditioned at (23 ± 2) °C before testing in accordance with Table 7.

8.2 Requirements

When tested in accordance with the test methods as specified in Table 7 using the indicated parameters, the fittings shall have physical characteristics conforming to the requirements given in Table 7.

Table 7 — Physical characteristics

Characteristic	Requirements	Test parameters		Test method
		Parameter	Value	
Oxidation induction time (Thermal stability)	> 20 min	Test temperature Number of test pieces ^a	200 °C ^b 3	ISO/FDIS 11357-6 of 2008
Melt mass-flow rate (MFR)	After processing maximum deviation of ± 20 % of the value measured on the batch used to manufacture the fitting	Loading mass Test temperature Time Number of test pieces ^a	5 kg 190 °C 10 min Shall conform to EN ISO 1133:2005	EN ISO 1133:2005
<p>a The numbers of test pieces given indicate the numbers required to establish a value for the characteristic described in the table. The numbers of test pieces required for factory production control and process control should be listed in the manufacturer's quality plan. For guidance see CEN/TS 1555-7 [7].</p> <p>b Test may be carried out at 210 °C providing that there is a clear correlation to the results at 200 °C; in case of dispute the reference temperature shall be 200 °C.</p>				

9 Performance requirements

When fittings conforming to this standard are assembled to each other or to components conforming to other parts of EN 1555, the joints shall conform to prEN 1555 5:2008.

10 Marking

10.1 General

10.1.1 Unless otherwise stated in Table 8, the marking elements shall be printed or formed directly on the fitting in such a way that after storage, weathering, handling and installation legibility is maintained during the use of the fitting.

NOTE The manufacturer is not responsible for marking being illegible, due to actions caused during installation and use such as painting, scratching, covering of the components or using detergents etc. on the components unless agreed or specified by the manufacturer.

10.1.2 Marking shall not initiate cracks or other types of defects which adversely influence the performance of the fitting.

10.1.3 If printing is used, the colour of the printed information shall differ from the basic colour of the fitting.

10.1.4 The size of the marking shall be such that it is legible without magnification.

10.1.5 There shall be no marking over the minimum spigot length of fittings.

10.2 Minimum required marking

The minimum required marking shall conform to Table 8.

Table 8 — Minimum required marking

Aspects	Mark or symbol
Number of the System Standard ^a	EN 1555
Manufacturer's name and/or trademark	Name or symbol
Nominal outside diameter(s) of pipe, d_n	e.g. 110
Material and designation	e.g. PE 80
Design application series (ie design SDR)	e.g. SDR 11
Applicable SDR fusion range of pipe ^a	e.g. SDR 11 - SDR 26
Manufacturer's information	^b
Internal fluid ^a	Gas
^a This information may be printed on a label associated with the fitting or on an individual bag. ^b For providing traceability, the following details shall be given: <ul style="list-style-type: none"> – the production period, year and month, in figures or in code; – a name or code for the production site if the manufacturer is producing in different sites. 	

10.3 Additional marking

Additional information relative to the fusion conditions (e.g. fusion and cooling time) and to the assembly torque, only for mechanical fittings, may appear on a label, which may be attached to a fitting or may be separate from the fitting.

Fittings conforming to this standard, which are third party certified by a certification body, may be marked accordingly.

11 Delivery conditions

The fittings shall be packaged in bulk or individually protected where necessary in order to prevent deterioration. Whenever possible, they shall be placed in individual bags, in cardboard boxes or cartons.

The cartons and/or individual bags shall bear at least one label with the manufacturer's name, type and dimensions of the part, number of units in the box, and any special storage conditions and storage time limits.

NOTE Fittings should be stored in their original packing, until ready for use.

Annex A (informative)

Examples of typical terminal connection for electrofusion fittings

A.1 Figures A.1 and A.2 illustrate examples of terminal connections suitable for use with voltages less than or equal to 48 volts (types A and B).

Dimensions in millimetres

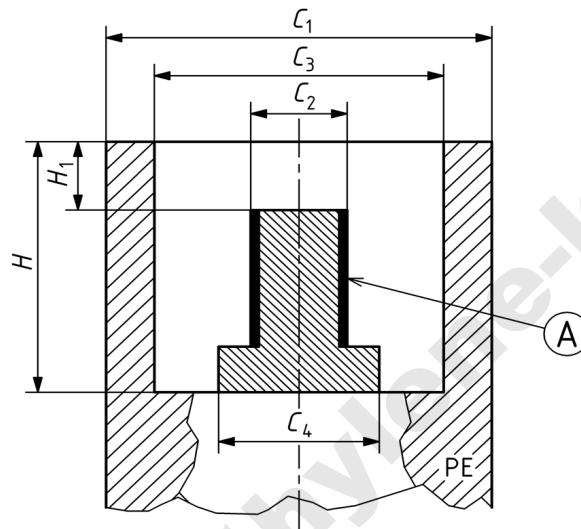

Key	
<p><i>A</i> active zone</p> <p>C_1 outside diameter of the terminal shroud</p> <p>C_2 diameter of the active part of the terminal</p> <p>C_3 internal diameter of the terminal</p> <p>C_4 maximum overall diameter of the base of the active part</p> <p>H internal depth of the terminal</p> <p>H_1 distance between the upper part of the terminal shroud and the active part</p> <p>H_2 height of the active part</p>	<p>$C_1 \geq 11,8$</p> <p>$C_2 = 4,00 \pm 0,03$</p> <p>$C_3 = 9,5 \pm 1,0$</p> <p>$C_4 \leq 6,0$</p> <p>$H \geq 12,0$</p> <p>$H_1 = 3,2 \pm 0,5$</p> <p>$H_2 \geq 7$</p> <p>$H_2 \leq H - H_1$</p>

Figure A.1 — Typical type A connection

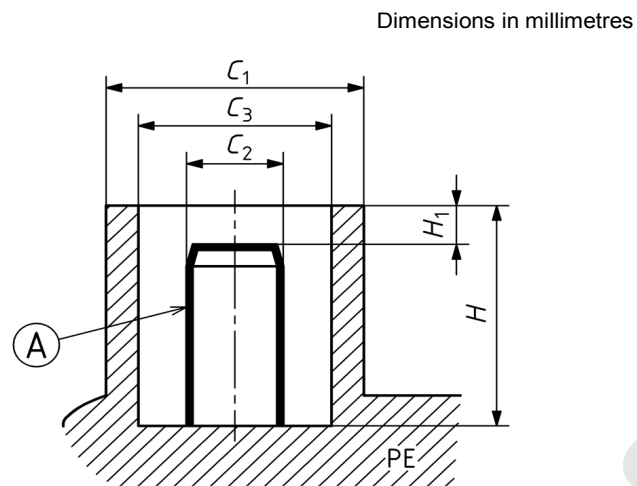
**Key**

<i>A</i>	active zone	
C_1	outside diameter of the terminal shroud	$C_1 = 13,00 \pm 0,5$
C_2	diameter of the active part of the terminal	$C_2 = 4,70 \pm 0,03$
C_3	internal diameter of the terminal	$C_3 = 10,0^{+0,5}_0$
H	internal depth of the terminal	$H \geq 15,5$
H_1	distance between the upper part of the terminal shroud and the active part	$H_1 = 4,5 \pm 0,5$

Figure A.2 — Typical type B connection

A.2 Figure A.3 illustrates an example of a typical terminal connection suitable for use with voltages up to 250 V (type C).

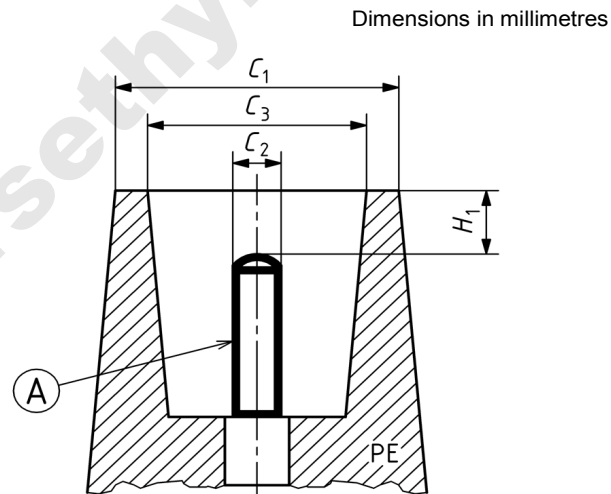
**Key**

<i>A</i>	active zone	
C_1	outside diameter of the terminal shroud	$C_1 \geq C_3 + 2,0$
C_2	diameter of the active part of the terminal	$C_2 \geq 2,0$
C_3	internal diameter of the terminal	$C_3 \geq C_2 + 4,0$
H_1	distance between the upper part of the terminal shroud and the active part	H_1 : sufficient to ensure a degree of protection of IP 2 X as defined in IEC 60529:2001 [8])
H_2	height of the active part	$H_2 \geq 7,0$

Figure A.3 — Typical type C connection

Annex B (normative)

Short-term pressure test method

B.1 Principle

A test piece, consisting of an electrofusion fitting assembled with one or more PE pipes having reduced free length sufficient to suppress pipe failure and create preferential failure in the fitting or in the connecting pipe-to-fitting joint, is placed in a controlled-temperature environment and subjected to an essentially continually increasing internal hydraulic pressure until failure occurs. The method is designed to establish the short-term failure pressure of the fitting/pipe assembly.

B.2 Apparatus

B.2.1 Constant-temperature water bath, in accordance with EN ISO 1167-1:2006, capable of being maintained at (20 ± 2) °C.

B.2.2 Pressure test equipment, in accordance with EN ISO 1167-1:2006, capable of applying a continuously increasing internal hydraulic pressure at a rate of (5 ± 1) bar/min³⁾ until the test piece fails.

B.2.3 Pressure gauge, having an accuracy of not less than 1 % of full-scale deflection and with a hand which indicates the maximum pressure reached.

A gauge shall be used that will indicate the failure pressure at approximately mid-scale. The gauge should preferably be equipped with a surge protection device.

The gauge shall be located in a position within the pressure system such that it will indicate the internal pressure of the test piece without being affected by pressure transients within the pressure supply lines, etc.

B.3 Test piece

The test piece shall be an assembly of one or more electrofusion fittings connected to PE pipes, with a minimum free pipe length between fittings of any type not exceeding d_n .

The pipes used shall be the thickest-walled pipe for which the fitting has been designed.

The test piece shall be closed with type A end caps in accordance with EN ISO 1167-1:2006.

B.4 Procedure

Attach the end caps to the test piece and fill it with water at ambient temperature.

Connect the test piece to the pressure source, ensuring that no air is trapped in the test assembly.

Immerse the test piece in the constant-temperature bath and condition it at (20 ± 2) °C for at least as long as the period defined in EN ISO 1167-1:2006 for the appropriate pipe wall thickness.

³⁾ 1 bar = 0,1 MPa = 10^5 Pa; 1 MPa = 1 N/mm²

Increase the pressure uniformly at a rate of (5 ± 1) bar/min until failure of the test piece occurs.

Record the pressure at failure.

After testing, inspect the test piece and record the location and mode of failure.

B.5 Test report

The test report shall include the following information:

- a) reference to EN 1555-3;
- b) all details necessary for complete identification of the pipes and socket fusion fittings used, including manufacturer, type of material and size of fitting and pipe;
- c) details of the fusion-jointing procedure used to assemble the test piece;
- d) pressure at failure;
- e) time to failure;
- f) failure location;
- g) mode of failure, e.g. ductile in fitting, brittle along fusion interface;
- h) any factor that could have affected the results, such as any incidents or operating details not specified in this annex;
- i) date of test.

www.parsethylene-kish.com

Annex C (normative)

Tensile test for fitting/pipe assemblies

C.1 Principle

A test piece consisting of an electrofusion fitting and two connecting PE pipes is subjected to an increasing tensile load at a constant pulling rate until ductile pipe failure occurs. The test is conducted at a constant temperature and is intended to simulate the creation of longitudinal tensile loading along a pipeline as a consequence of external mechanical interference. Rupture of the fitting or the connecting fusion joints is not an acceptable failure mode.

C.2 Apparatus

This shall be in accordance with ISO 13951, with the additional requirement that the tensile-testing machine shall be capable of accommodating a test piece elongation of 25 % and of sustaining a constant test speed of $(5 \pm 1,25)$ mm/min.

C.3 Test piece

The test piece shall be in accordance with ISO 13951.

In cases where $d_n \geq 180$ mm and where the conduct of tensile tests on fitting/pipe assemblies is beyond the limits of the available test equipment, the testing of joint segments may be appropriate. Testing of segment test pieces shall not be undertaken, however, unless a correlation with testing of complete pipe/joint assemblies has been established.

C.4 Procedure

This shall be in accordance with ISO 13951, but without that International Standard's requirement for the load to be constant. The pulling rate shall be $5 \text{ mm/min} \pm 25 \%$, sustained until a test piece elongation of 25 % is reached.

C.5 Test report

The test report shall include the following information:

- a) reference to EN 1555-3;
- b) all details necessary for complete identification of the pipes and electrofusion fittings used, including manufacturer, type of material and size of fitting and pipe;
- c) details of the fusion-jointing procedure used to assemble the test piece;
- d) test temperature;
- e) leaktightness and integrity of the fitting and fusion joint after 25 % elongation of the test piece;
- f) any factor that could have affected the results, such as an incident or operating detail not specified in this annex;
- g) date of test.

Bibliography

- [1] prEN 1555-6, *Plastics piping systems for gaseous fuels supply — Polyethylene (PE) — Part 6: Recommended practice for installation*
- [2] EN 12007-2:2000, *Gas supply systems — Pipelines for maximum operating pressure up to and including 16 bar — Part 2: Specific functional recommendations for polyethylene (MOP up to and including 10 bar).*
- [3] IEC 60335-1:2006, *Safety of household and similar electrical appliances — Part 1: General requirements (IEC 335-1:1991, modified).*
- [4] IEC 60364-1:2005, *Electrical installations of buildings — Part 1: Fundamental principles, assessment of general characteristics, definitions.*
- [5] IEC 60449:1973, *Voltage bands for electrical installations of buildings.*
- [6] ISO 11922-1:1997, *Thermoplastics pipes for the conveyance of fluids — Dimensions and tolerances — Part 1: Metric series.*
- [7] CEN/TS 1555-7, *Plastics piping systems for the supply of gaseous fuels — Polyethylene (PE) — Part 7: Guidance for the assessment of conformity.*
- [8] IEC 60529:2001, *Degrees of protection provided by enclosures (IP code).*