

INTERNATIONAL
STANDARD

ISO
727-2

Second edition
2005-06-01

**Fittings made from unplasticized
poly(vinyl chloride) (PVC-U), chlorinated
poly(vinyl chloride) (PVC-C) or
acrylonitrile/butadiene/styrene (ABS) with
plain sockets for pipes under pressure —**

**Part 2:
Inch-based series**

*Raccords en poly(chlorure de vinyle) non plastifié (PVC-U), en
poly(chlorure de vinyle) chloré (PVC-C) ou en
acrylonitrile/butadiène/styrène (ABS), à emboîtements lisses pour tubes
sous pression —*

Partie 2: Série basée sur les inches



Reference number
ISO 727-2:2005(E)

www.parsethylene-kish.com

Foreword

ISO (the International Organization for Standardization) is a worldwide federation of national standards bodies (ISO member bodies). The work of preparing International Standards is normally carried out through ISO technical committees. Each member body interested in a subject for which a technical committee has been established has the right to be represented on that committee. International organizations, governmental and non-governmental, in liaison with ISO, also take part in the work. ISO collaborates closely with the International Electrotechnical Commission (IEC) on all matters of electrotechnical standardization.

International Standards are drafted in accordance with the rules given in the ISO/IEC Directives, Part 2.

The main task of technical committees is to prepare International Standards. Draft International Standards adopted by the technical committees are circulated to the member bodies for voting. Publication as an International Standard requires approval by at least 75 % of the member bodies casting a vote.

Attention is drawn to the possibility that some of the elements of this document may be the subject of patent rights. ISO shall not be held responsible for identifying any or all such patent rights.

ISO 727-2 was prepared by Technical Committee ISO/TC 138, *Plastics pipes, fittings and valves for the transport of fluids*, Subcommittee SC 2, *Plastics pipes and fittings for water supplies*.

This second edition cancels and replaces the first edition (ISO 727-2:2002), which has been technically revised.

ISO 727 consists of the following parts, under the general title *Fittings made from unplasticized poly(vinyl chloride) (PVC-U), chlorinated poly(vinyl chloride) (PVC-C) or acrylonitrile/butadiene/styrene (ABS) with plain sockets for pipes under pressure*:

- Part 1: Metric series
- Part 2: Inch-based series

www-parsethylene-kish.com

www.parsethylene-kish.com

Fittings made from unplasticized poly(vinyl chloride) (PVC-U), chlorinated poly(vinyl chloride) (PVC-C) or acrylonitrile/butadiene/styrene (ABS) with plain sockets for pipes under pressure —

Part 2: Inch-based series

IMPORTANT — It is strongly recommended that the advice of the fittings manufacturer be sought in the selection of an appropriate type of solvent cement used to connect sockets to pipes, depending upon whether the cylindrical or conical type of socketed fitting is being used for a particular installation.

1 Scope

This part of ISO 727 specifies the dimensions, in millimetres, of plain sockets (cylindrical and conical), for the inch-based pipe series, in fittings made from unplasticized poly(vinyl chloride) (PVC-U), chlorinated poly(vinyl chloride) (PVC-C) or acrylonitrile/butadiene/styrene (ABS), intended for connecting by solvent cementing to pipes of the corresponding material for use under pressure. The resulting joint does not require mechanical anchorage.

2 Normative references

The following referenced documents are indispensable for the application of this document. For dated references, only the edition cited applies. For undated references, the latest edition of the referenced document (including any amendments) applies.

ISO 161-2:1996, *Thermoplastics pipes for the conveyance of fluids — Nominal outside diameters and nominal pressures — Part 2: Inch-based series*

3 Terms and definitions

For the purposes of this document, the following terms and definitions apply.

3.1

cylindrical socket

parallel socket

plain socket having a generally cylindrical form with similar root and mouth dimensions

NOTE In practice, such sockets are manufactured with a slight taper in order to assist in removing the moulded fitting from the moulding tool (see 4.1).

3.2 conical socket
 tapered socket
 plain socket having a designed taper opening up from root to mouth, and having less clearance than a cylindrical socket

3.3 mean inside diameter at mid-point of socket depth

d_{im}
 arithmetic mean of two diameters measured at right angles to each other at the mid-point of the socket depth

4 Socket dimensions

4.1 Cylindrical sockets

Cylindrical sockets (see Figure 1) shall conform to Table 1 for sockets made from PVC-U or PVC-C and to Table 2 for sockets made from ABS.

Socket sizes specified are based on the nominal outside diameters of thermoplastics pipes, d_n , according to ISO 161-2.

The maximum included angle α of the socketed portion of a fitting (taper of cylindrical socket) shall not exceed $0^\circ 40'$ for $\leq DN 2 \frac{1}{2}$ and $0^\circ 30'$ for $\geq DN 3$.

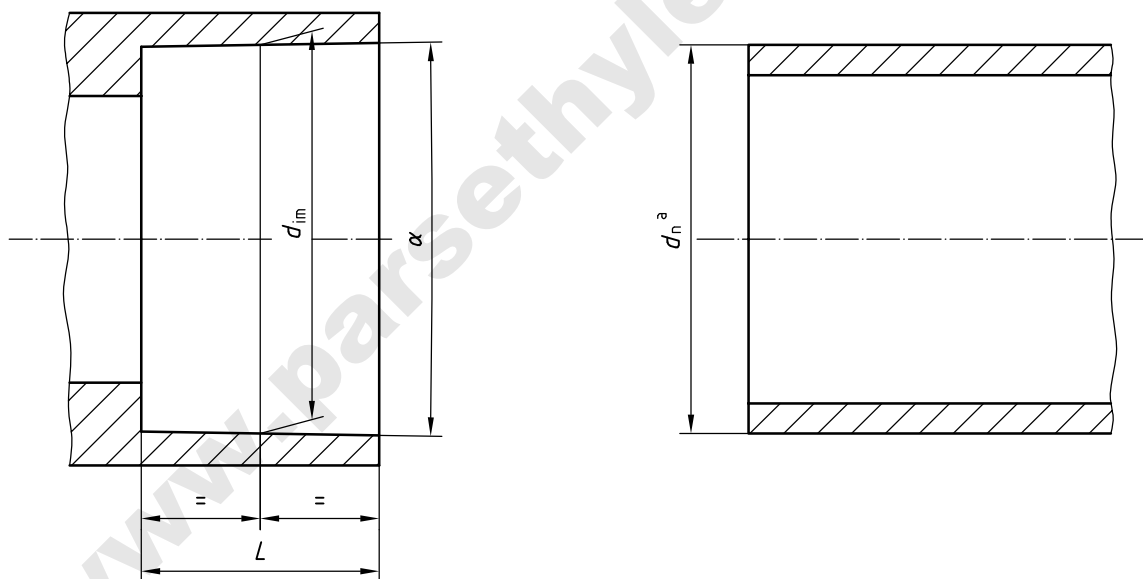

^a In accordance with ISO 161-2.

a) Socket

b) Pipe

Figure 1 — Dimensions of cylindrical sockets

Table 1 — Dimensions of cylindrical sockets made from PVC-U or PVC-C

Dimensions in millimetres

DN	Minimum socket length ^a <i>L</i>	Mean inside diameter at midpoint of socket depth		Out-of-roundness max.
		min.	max.	
3/8	14,5	17,1	17,3	0,25
1/2	16,5	21,3	21,5	0,25
3/4	19,5	26,7	26,9	0,25
1	22,5	33,5	33,7	0,25
1 1/4	27	42,2	42,4	0,3
1 1/2	30	48,2	48,4	0,4
2	36	60,3	60,5	0,5
2 1/2	43,5	75,1	75,3	0,6
3	50,5	88,8	89,1	0,7
3 1/2	56,5	101,6	101,9	0,7
4	63	114,2	114,5	0,8
5	76	140,1	140,4	1,0
6	90	168,2	168,5	1,2
7	103	193,7	194,0	1,4
8	115,5	219,0	219,4	1,6
10	142,5	272,8	273,4	2
12	168	323,7	324,3	2,3

NOTE The values given for *L* and d_{im} in this table have been taken from BS 4346-1:1969.

^a Due to the shrinkage behaviour of cylindrical sockets made from PVC-C, the socket length may be 1 mm shorter.

Table 2 — Dimensions of cylindrical sockets made from ABS

Dimensions in millimetres

DN	Minimum socket length <i>L</i>	Mean inside diameter				Out-of-roundness max.
		Socket mouth		Socket root		
		d_{s1}		d_{s2}		
		min.	max.	min.	max.	
3/8	14,5	17,1	17,3	16,9	17,3	0,25
1/2	16,5	21,3	21,5	21,1	21,4	0,25
3/4	19,5	26,7	26,9	26,4	26,8	0,25
1	22,5	33,5	33,7	33,2	33,6	0,25
1 1/4	27,0	42,2	42,5	41,9	42,3	0,3
1 1/2	30,0	48,2	48,6	47,9	48,3	0,4
2	36,0	60,3	60,7	60,0	60,4	0,5
3	50,5	89,0	89,3	88,5	88,9	0,6
4	63,0	114,4	114,8	113,9	114,3	0,8
6	90,0	168,4	168,8	167,8	168,3	1,2
8	115,5	219,3	219,9	218,7	219,1	1,6

NOTE The values given for L , d_{s1} and d_{s2} in this table have been taken from BS 5392-1:1976.

Table 3 — Dimensions of conical sockets made from PVC-U or PVC-C

Dimensions in millimetres

DN	Minimum socket length ^a <i>L</i>	Mean inside diameter				Out-of-roundness max.
		Socket mouth		Socket root		
		<i>d_{s1}</i>		<i>d_{s2}</i>		
		min.	max.	min.	max.	
1/8	12,7	10,49	10,69	10,08	10,28	0,41
1/4	15,9	13,92	14,12	13,51	13,71	0,41
3/8	19,1	17,35	17,55	16,94	17,14	0,41
1/2	22,2	21,44	21,64	21,13	21,33	0,41
3/4	25,4	26,77	26,97	26,47	26,67	0,51
1	28,6	33,53	33,79	33,14	33,40	0,51
1 1/4	31,8	42,29	42,55	41,91	42,17	0,61
1 1/2	34,9	48,41	48,71	47,96	48,26	0,61
2	38,1	60,48	60,78	60,02	60,32	0,61
2 1/2	44,5	73,20	73,56	72,67	73,03	0,76
3	47,6	89,11	89,51	88,5	88,9	0,76
3 1/2	54	101,81	102,21	101,2	101,6	0,76
4	57,2	114,53	114,99	113,84	114,30	0,76
5	66,7	141,56	142,06	140,8	141,3	1,52
6	76,2	168,55	169,11	167,72	168,28	1,52
8	101,6	219,46	220,22	218,32	219,08	2,29
10	127,0	273,43	274,19	272,29	273,05	2,54
12	152,4	324,23	324,99	323,03	323,85	3,05

NOTE The values in this table have been taken from ASTM D 2467:2004 and ASTM F 439:2002.

^a Rounded to 1/10 of a millimetre.

5 Marking

The identification of the different types of plain socket (cylindrical and conical) shall be reflected in the minimum required marking for the relevant product and shall be included in the corresponding product standard.

Bibliography

- [1] BS 4346-1:1969, *Joints and fittings for use with unplasticized PVC pressure pipes — Injection moulded unplasticized PVC fittings for solvent welding for use with pressure pipes, including potable water supply*
- [2] BS 5392-1:1976, *Specification for acrylonitrile-butadiene-styrene (ABS) fittings for use with ABS pressure pipe — Fittings for use with pipe for industrial uses*
- [3] ASTM D 2467:2004, *Standard Specification for Poly(Vinyl Chloride) (PVC) Plastic Pipe Fittings, Schedule 80*
- [4] ASTM F 439:2002, *Standard Specification for Chlorinated Poly(Vinyl Chloride) (CPVC) Plastic Pipe Fittings, Schedule 80*

www.parsethylene-kish.com